

Development of spider queen non-playable character in miner quest game using finite state machine

Raja Ilham Maulidani Gumelar¹, Purba Daru Kusuma¹, Ashri Dinimaharawati¹

¹Department of Computer Engineering, School of Electrical Engineering, Telkom University, Indonesia

Article Info

Article history:

Received July 02, 2023

Revised July 23, 2023

Accepted July 24, 2023

Keywords:

Educational Game
Finite State Machine
Artificial Intelligence
NPC
Mining Materials

ABSTRACT

Technology's rapid advancement has transformed various aspects of our lives, including education. Learning games has become a prominent development, but there's a lack of age-appropriate options for young children. To address this, the study introduces Spider Queen. This friendly, non-playable character has a mining-themed visual in the educational game Miner Quest, designed for kindergarten using the finite state machine. The results of this study prove that the Miner Quest game effectively enhances responsiveness, expands knowledge, and paves the way for future educational game development. It emphasizes the importance of interactive approaches for engaging learning experiences for young children.

This is an open-access article under the [CC BY-SA](https://creativecommons.org/licenses/by-sa/4.0/) license.



Corresponding Author:

Raja Ilham Maulidani Gumelar
Department of Computer Engineering
School of Electrical Engineering, Telkom University
Bandung, Indonesia
Email: railhamm@telkomuniversity.ac.id

1. INTRODUCTION

The rapid advancement in technology has revolutionized various aspects of our lives, leading to significant changes in how we communicate, work, and interact. As technology evolves at an unprecedented pace, it becomes crucial to delve into its multifaceted implications, challenges, and opportunities to comprehend its profound impact on society and explore strategies for effectively harnessing its potential for the betterment of humanity. In this case, technological progress is rapidly progressing, significantly influencing education globally. An example of this progress within education is using games for learning purposes. Integrating these games into the classroom not only enhances traditional teaching approaches but has also garnered significant attention as a subject of research [1].

Currently, games are widespread on various platforms, including the web, desktop, and mobile. However, only a few of these games are educational, which is unfortunate. Many games are designed for adults and may not be suitable for children. As a result, there needs to be more age-appropriate educational games that can meet young individuals' learning and developmental needs. Therefore, numerous games support education. Play can help the learning objective [2]. For example, gamified activity has been used to improve the performance of new English learning [3]. The other example is using serious games like Like2be to support the individual career orientation process [1]. Serious games are also essential to minimize school phobia, making learning more fun [1].

A critical aspect of video games is the presence of non-playable characters (NPCs). These NPCs exist within the game environment but are not controlled by the player. This concept of non-playable characters, commonly abbreviated as NPCs, can be traced back to the origins of traditional tabletop RPGs (Role-Playing Games). In these RPGs, the players assume the role of storytellers, narrating the actions and decisions of the

characters within the game through engaging storytelling techniques. Thus, NPCs play a pivotal role in enhancing players' immersive and interactive experience, adding depth, complexity, and unpredictability to the game world. Their inclusion in games has evolved, with advancements in technology enabling more sophisticated and realistic portrayals of NPCs, further enriching the overall gaming experience for players [4].

A significant problem in game development, especially for educational ones, is the lack of age-appropriate non-playable characters for kindergarten children. In this case, non-playable characters have a non-threatening visual based on the mining theme.

Based on this problem, this work is aimed to propose the development of a non-playable character called Spider Queen, which is a non-playable character that is age appropriate for the kindergarten student. Spiderqueen also has a non-threatening visual and is based on mining themed. This non-playable character is part of an educational game called Miner Quest. Miner Quest is a platformer game designed as an alternative learning media for introducing mining materials, specifically those found in Indonesia.

2. LITERATURE REVIEW

2.1 Video Game Development

A video game serves as a medium through which a player engages in interactive experiences with a machine equipped with an electronic visual display. In addition to potentially involving other players, this interaction is facilitated by a purposeful fictional setting that adds depth and meaning to the gameplay. The player's emotional connection to the outcomes of their actions within this mythical context further sustains their engagement and involvement in the game. Thus, a video game can be seen as a multifaceted platform where players form connections not only with technology but also with the virtual world and its narrative elements, fostering a rich and immersive gaming experience [5]. Playing games individually can also enhance brain skills as players are required to tackle conflicts or challenges and find solutions to various missions within the game. Additionally, games can stimulate cognitive development in children, improving brain capabilities in terms of concentration and problem-solving abilities [6].

As the gaming field progressed, the genre of games underwent a process of classification, resulting in various distinct categories, such as simulation games, action games, puzzle games, educational games, platform games, adventure games, and so on [7]. For example, platform games are games where the characters and environments are presented in a side view rather than a top-down view. This perspective creates a visual representation of vertical movement, emphasizing the concept of "up" and "down" as suggested by the term "platform." Adventure games are a genre characterized by their reliance on a storyline that drives the gameplay. "adventure" is commonly associated with a structure reminiscent of a quest. Puzzle games inherently possess a solution. Specifically, a maze puzzle is a game that involves navigating a combination of paths, often from starting point to a destination, emphasizing the concept of finding and maneuvering through a specific route [7].

Table 1. List of several games, including the objective and protagonist NPC.

No	Game	Protagonist	Game Objective
1	Super Mario Bros	Mario	Defeat Bowser and Rescue Princess Toadstool
2	The Legend of Zelda	Link	Collect eight pieces of the Triforce of Wisdom, defeat Ganon, and Rescue Princess Zelda.
3	Sonic The Hedgehog	Sonic	Collect the Chaos Emerald and Defeat Dr. Eggman
4	Metal Gear Solid 1	Solid Snake	Infiltrates a nuclear weapons facility to neutralize the terrorist threat
5	Assassin's Creed Unity	Arno Victor Dorian	Avenge foster father's death at the hands of the Templars leads to the discovery of an internal conflict between the Templars because of the French Revolution.
6	Plant VS Zombie	Crazy Dave	Prevent zombies from entering the house
7	Farcry 3	Jason Brody	After a vacation goes awry, protagonist Jason Brody, an ordinary American tourist, must learn the ways of the jungle to survive and rescue his friends, who have been captured by the insane Vaas Montenegro and his gang of pirates to be sold into slavery.
8	WatchDogs	Aiden Pearce	Follow Aiden quest for revenge after the killing of his niece
9	Pokemon Red	Red	Become the champion, using the Pokemon you capture along the way
10	This work	Tito the Miner	Collect mining materials

In game development, the behavior of non-playable characters (NPCs) is pivotal in shaping the player's experience. A non-playable character is an object or a character in a game that can be a human, animal, monster, etc., that the player cannot control. However, they can act and perform activities as if possessed by the player. Still, these NPCs are controlled by artificial intelligence, which enables them to carry out actions within the game [8]. One of the essential actions in the NPC is combat action. During combat, NPC requires strategies to

Development of spider queen non-playable character in miner quest game using finite state machine (Raja Ilham Maulidani Gumelar)

avoid being easily defeated, including introducing behavioral variations toward the player. The finite state machine (FSM) is one method that governs these player behavior variations. A finite state machine (FSM) is one of the control system design methods that describe behavioral variations using three elements: state(condition), event(occurrence), and action [9].

In every game, there are goals that players must achieve. These objectives serve as guides in embarking on exciting and captivating adventures. Whether saving the world, uncovering hidden mysteries, or achieving victory in a competition, video games offer thrilling challenges that stir the heart and provide a satisfying sense of accomplishment [10].

2.2 Mining Products in Indonesia

Indonesia is a vast archipelagic country. In addition to its large territory, Indonesia is also rich in abundant natural resources. Indonesia is blessed with great renewable natural resources, including but not limited to water, wind, sunlight, and air [11], found in copious amounts across its vast and diverse landscape. Furthermore, Indonesia, a country known for its abundant non-renewable natural resources, boasts an impressive array, including gold [12], coal [13], and even nickel [14], making it a valuable global source.

3. METHOD

3.1 Miner Quest Game State Diagram

A state diagram serves as a visual representation of a system of multiple states created using diagrams or symbols to facilitate understanding of the transition among states. The following is the state diagram of the Miner Quest Game. Figure 1 depicts the state chart diagram design used in the Miner Quest game. A detailed explanation of the state diagram in the Miner Quest game can be found in Table 2.

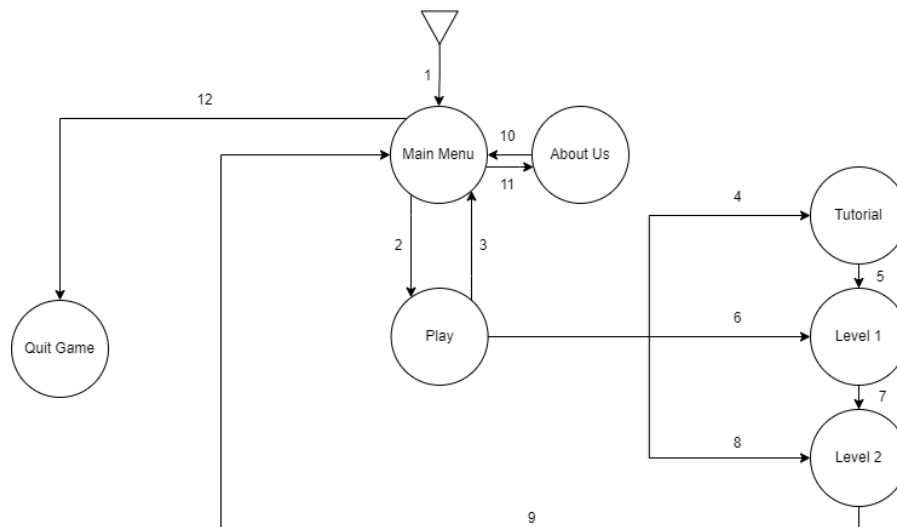

Figure 1. Miner quest game state chart diagram

Table 2. State explanation in the Miner Quest game.

No	Event	Flow Description
1	The player enters the game	Enter the main menu
2	The player selects the play menu	Enter the play menu, which contains levels in the game
3	The player selects back to the menu	Enter the main menu
4	The player selects the tutorial level	Enter the tutorial level
5	The player completes the tutorial level	Proceed to level 1
6	The player selects level 1	Enter level 1
7	The player completes level 1	Proceed to level 2
8	The player selects level 2	Enter level 2
9	The player completes level 2	Display the main menu
10	The player selects About Us	Enter the About Us menu
11	The player selects back to the menu	Enter the main menu
12	The player selects Quit game	Exit the game

3.2 Game Control

Miner Quest is operated using a keyboard as the control for the main character and as a tool to select the available menus in the Miner Quest game.



Table 3. Main characters and menus control in the game

Button	Function
main menu	
Up Arrow / ↑	to move the selection upwards
Down Arrow / ↓	to move the selection downwards
Enter	to select from the menu
Up Arrow / ↑	to move the selection upwards
in-game	
Right or Left Arrow / ↔	character controls to move left or right
Up Arrow / ↑	jump
S	shoot
Esc	pause the game

3.3 Characters Design

Characters design is a crucial aspect in games to enhance the visual appearance and attract players' interest to play the game. Here are the character's designs for the Miner Quest game with 2-dimensional graphics.

Table 4. Characters Design

Character Illustration	Name	Explanation	Object Size (in Pixel)
	Tito the Miner	Main Character	80x80 Pixel
	Spider Queen NPC	Enemy Boss NPC	257x257 px

A Spider refers to an arachnid belonging to the order Araneae. Spiders are characterized by their eight legs and two body segments. They are known for their ability to spin silk, which they use to construct webs for capturing prey, create egg sacs, or build shelters.

Spiders are found in diverse habitats worldwide, including forests, deserts, caves, and even human dwellings. They are carnivorous predators, primarily feeding on insects and other small invertebrates. They use venomous fangs to inject venom into their prey, immobilizing or killing the game before consumption.

[15]

3.4 Spider Queen NPC Design

In the Miner Quest, a non-playable character (NPC) called Spider Queen is designed using the finite state machine method. This section will explain how the Spider Queen NPC works using the finite state machine method, depicted in a diagram.

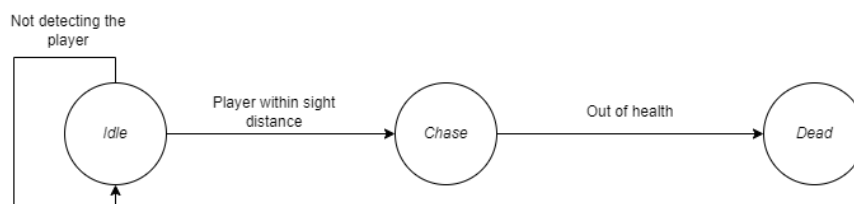

Figure 2. Spider Queen diagram state

Figure 2 is the state diagram of the Spider Queen NPC, which consists of three states: idle, chase, and dead. The explanation of Figure 2 is as follows: the Spider Queen NPC starts in the idle state when the player is not within sight of the Spider Queen NPC. When the player enters the sight distance for the first time, the Spider Queen NPC detects the player and transitions to the chase state. The Spider Queen NPC transitions to the dead state when it reaches the hurt state with the remaining life points.

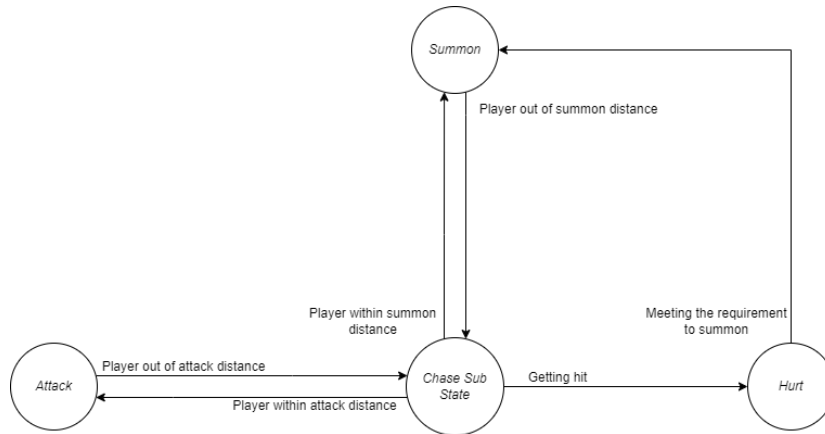

Figure 3. Spider Queen chase substate diagram

Figure 3 is the substate diagram of the chase state, which consists of four states: chase substate, attack, summon, and hurt. The explanation of Figure 3 is as follows: when the Spider Queen NPC is in the chase state, it also enters a substate called the chase substate. In the chase substate, the Spider Queen NPC transitions to one of the three available states: attack, summon, or hurt. The Spider Queen NPC enters the attack state when the player enters the attack distance and returns to the chase substrate when the player moves out of the attack distance. If the player is within the summon distance and meets the requirements of the summon state, the Spider Queen NPC enters the summon state, and it returns to the chase substrate when the player moves out of the summon distance. As for the hurt state, the Spider Queen NPC transitions to the hurt state when the player attacks it. If the Spider Queen NPC transitions to the hurt state more than ten times, it meets the requirements for the summon state and returns to the chase state.

3.5 Black Box Testing

Black box testing is a software testing technique employed to assess the functionality of an application. Its primary objective is to analyze the expected outputs for various input values available to the application. This testing approach relies on the software requirement and specification. It involves testing the item without any knowledge of its internal workings. This technique derives its name from the fact that the tester is not required to know the internal code implementation of the application. [16]

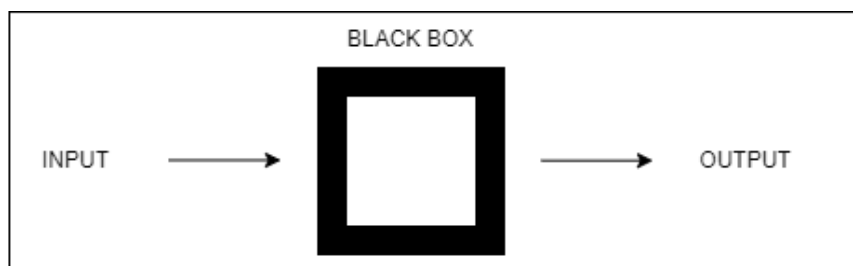

Figure 4. Black box testing illustration.

3.6 Qualitative Descriptive Method

The qualitative descriptive method captures detailed insights into a phenomenon without complex theoretical explanations. It aims to comprehensively describe real-life experiences and perspectives using

techniques like interviews, observations, or focus groups. Representing participants' voices through direct quotes and narratives offers a holistic view of the studied phenomenon. This approach is valuable for exploring new areas and gaining a deeper understanding of a topic in various fields of study [17].

4. RESULTS AND DISCUSSION

The functional test determines if the created NPCs align with the design regarding their states, inputs, and generated outputs. The functional tests are conducted using the black box testing method. The testing results of NPCs can be seen in Table 5.

Table 5. Functional testing on Spider Queen NPC

State	Functional	Result
idle	remain inactive state until the player enters the sight distance	matching
chase	chasing the player within the NPC sight distance	matching
chase	chasing the player within the NPC sight distance	matching
substate	chasing the player within the NPC sight distance	matching
attack	attacking the player within the NPC attack distance	matching
summon	summoning spider NPCs when a player is within the summoning range	matching
hurt	receives damage resulting in a health reduction	matching
dead	health reaches zero and becomes inactive	matching

The user testing was conducted through a Q&A interview with several respondents of various elements presented in Amalia kindergarten based in Bandung, West Java, Indonesia. The reason for choosing this interview target is because this research is resulting in the development of a game project specifically designed for kindergarten students. The interviews were conducted after the respondents played the Miner Quest game, and then the results will be presented using the qualitative descriptive method. The interview material focused on the game itself. Six respondents were selected to participate in this interview because only a few were willing to be interviewed. The six respondents comprised three kindergarten student representatives, two parents, and one kindergarten teacher. The detailed description and interview results can be seen in Table 6.

Table 6. User response result

Respondent	Age (by years)	Job	Statement
1	7	kindergarten student	"The game being played is exciting, and some obstacles are challenging. Additionally, the difficulty level of the Spider Queen boss is tougher than the Golem boss, and I want to replay the game from start to finish."
2	6	kindergarten student	"For the second difficulty level, neither of the fought bosses is difficult, but if I had to choose, I would prefer to fight the golem boss."
3	6	kindergarten student	"The game played is highly entertaining, and the difficulty level of the bosses is higher, especially the golem boss due to its immense power. I will replay the game Miner Quest if bosses have a higher difficulty level than the golem boss."
4	38	mother of the first respondent	"My daughter is a curious child. When faced with game difficulties, she will keep trying until she succeeds. She enjoys role-playing games like Roblox and similar ones. During gameplay, she often uses her imagination, even applying the objectives that must be achieved in the game to her daily life."
5	34	mother of the second respondent	"My son often plays games on his mobile phone and enjoys action games like Call of Duty. Playing games like Super Mario Bros is easy for him, and if given similar games, he has no difficulty playing it."
6	53	kindergarten teacher	"For this research, we are unaware of the impact that would occur if this research were not conducted. We also know that parents provide games to their children with varying frequencies, ranging from once a day to once a week, while no games are provided to them at school. This research can be carried out because giving games to children only once will not lead to addiction; addiction only occurs when it is repeated. Additionally, this game can train children's responsiveness to instructions and game objectives quickly and effectively, considering that each child has different speeds and abilities in executing these instructions and objectives. Furthermore, the teachers want to know the observation results of children regarding the use of this game."

After the interviews, the information based on Table 6 will be converted into descriptive details. Based on Table 6, Varied results were found. Generally, young children enjoy playing games. This can be seen from the statements of the first, second, and third respondents, who are kindergarten students. All three respondents only provided opinions about the Miner Quest game. Two of the three kindergarten students gave positive statements, stating that the Miner Quest game is delightful and that they feel challenged to complete the

Development of spider queen non-playable character in miner quest game using finite state machine (Raja Ilham Maulidani Gumelar)

objectives. However, one of the three respondents disagreed, considering Miner Quest an ordinary game. They all also commented on the boss enemies in the Miner Quest game. Respondents two and three believed that the Golem boss is more difficult to defeat than the Spider Queen boss. In contrast, the first respondent had the opposite opinion, finding the Spider Queen boss more challenging to defeat than the Golem boss.

Parents have biological, emotional, and social roles in guiding, raising, and caring for children. They also serve as role models, guides, and supporters in the development and education of their children [18]. This can be observed from the statements of the fourth and fifth respondents, parents or guardians of some kindergarten students. They are more interested in providing opinions on their children's knowledge development and responses influenced by a game. The fourth respondent believes that a match enhances their child's problem-solving knowledge, as seen in their response to completing objectives in a game. They also added that games teach their child to use their imagination in solving problems within a game. On the other hand, the fifth respondent believes their child can quickly complete the objectives in the Miner Quest game because they have a high problem-solving response, influenced by their child's fondness for playing games on their mobile devices.

Kindergarten teachers have an essential role in the early lives of young children. They create a pleasant, creative, and interactive learning environment where young children can develop social, cognitive, and interactive skills [19]. This can be seen from the statement of the sixth respondent, a kindergarten teacher, who is more interested in providing opinions about the impact of an educational game on their students. They believe that giving a game with varying frequencies can differentiate their students' ability to follow instructions, distinguishing those who can quickly execute instructions from those who are slower. They also question whether an educational game can enhance their students' response to education and objectives.

Here, we obtained varied results from the analysis of the respondents. Firstly, an educational game can positively impact kindergarten children, such as improving their response speed to instructions and engaging the right brain, resulting in imaginative thinking from an early age in achieving game objectives. Secondly, providing games with different frequencies can yield different outcomes. Kindergarten children who are regularly given games by their parents daily can quickly complete instructions and objectives in the Miner Quest game without difficulty facing the boss's enemies. In contrast, kindergarten children whose parents rarely give games can only achieve instructions and goals through repetition and struggle to overcome the boss enemies in the Miner Quest game.

5. CONCLUSION

After conducting thorough implementation and testing of the Miner Quest game, which introduces mining outcomes and practical applications, several significant conclusions have been drawn. User testing demonstrates the game's effectiveness in benefiting kindergarten children by enhancing their responsiveness to instructions and objectives and improving cognitive and motor skills. Additionally, Miner Quest expands their knowledge and comprehension of mining materials from an early age. Qualitative interviews reveal a highly positive response from users, highlighting the game's entertainment value and potential as an educational resource. This suggests Miner Quest could be a benchmark for developing similar educational games, meeting the unique needs of young learners. By integrating educational content with entertainment elements, Miner Quest creates an engaging and interactive learning environment, fostering motivation and enthusiasm. These outcomes offer valuable insights into educational game design and its impact on cognitive and behavioral development. In conclusion, Miner Quest is an effective educational tool, enhancing responsiveness, expanding knowledge, and serving as a reference for future game development. It emphasizes the importance of interactive approaches for compelling learning experiences.

REFERENCES

- [1] C. Keller, A. K. Döring, and E. Makarova, "Factors influencing the effectiveness of serious gaming in the field of vocational orientation," *Education Sciences*, vol. 13, no. 1, p. 16, Dec. 2022, doi: 10.3390/educsci13010016.
- [2] H.-T. Hou, "Diverse development and future challenges of game-based learning and gamified teaching research," *Education Sciences*, vol. 13, no. 4, p. 337, Mar. 2023, doi: 10.3390/educsci13040337.
- [3] Y.-C. Wang, "Gamification in a news English course," *Education Sciences*, vol. 13, no. 1, p. 90, Jan. 2023, doi: 10.3390/educsci13010090.
- [4] G. Silva and M. Souza Ribeiro. "Development of non-player character with believable behavior: a systematic literature review", *Companion Proceedings of the 20th Brazilian Symposium on Games and Digital Entertainment*, Online, pp. 319-323, 2021, doi: https://doi.org/10.5753/sbgames_estendido.2021.19660.
- [5] J. Arjoranta, "How to define games and why we need to", *The Computer Games Journal*, vol. 8, p. 109-120, 2019, doi: 10.1007/s40869-019-00080-6.
- [6] U.N. Ebere, U.N. Ukamaka, and U.J. Nnenna, "Video games role in childhood studying: impacts and implications", *IDOSR Journal of Communication and English*, vol. 7, no. 1, pp.62-62, 2022.
- [7] A. A. Qaffas, "An operational study of video games' genres", *Int. J. Interact. Mob. Technol.*, vol. 14, no. 15, pp. 175-194, Sep. 2020, doi: 10.3991/ijim.v14i15.16691.
- [8] E. Alonso, M. Peter, D. Goumar, and J. Romoff, "Deep reinforcement learning for navigation in AAA video games", *arXiv*, 2020,

- doi : <https://doi.org/10.48550/arXiv.2011.04764>.
- [9] D. Jagdale, "finite state machine in game development", *IJARSCT*, vol. 10, no. 1, pp. 384-390, 2021, doi : <https://doi.org/10.48175/IJARSCT-2062>.
- [10] F. Schröter and J.N. Thon, " Video game characters theory and analysis ", *Interdisciplinary E-Journal for Narrative Research*, vol. 3, p.40, 2014.
- [11] J. Langer, J. Quist, and K. Blok, "Review of renewable energy potentials in Indonesia and their contribution to a 100% renewable electricity system," *Energies*, vol. 14, no. 21, p. 7033, Oct. 2021, doi: 10.3390/en14217033.
- [12] A. A. Meutia, R. Lumowa, and M. Sakakibara, "Indonesian Artisanal and Small-Scale Gold Mining—A Narrative Literature Review," *International Journal of Environmental Research and Public Health*, vol. 19, no. 7, p. 3955, Mar. 2022, doi: 10.3390/ijerph19073955.
- [13] E. Endri, A. P. Utama, A. Aminudin, M. S. Effendi, B. Santoso, and A. Bahiramsyah, "Coal price and profitability: evidence of coal mining companies in Indonesia", *IJEPP*, vol. 11, no. 5, pp. 363–368, Aug. 2021, doi: 10.32479/ijepp.11503.
- [14] P. Tan, "Macroeconomic analysis of the Indonesian nickel industry using depest analysis", *Ultima Management : Jurnal Ilmu Manajemen*, vol. 14, no. 2, pp. 308-320, Dec. 2022, doi: 10.31937/manajemen.v14i2.2933.
- [15] H. Thomas and G. Dumas, "Spider ecology and behaviour—spiders as model organisms", *Insects*, vol. 14, no. 4, p. 330, Mar. 2023, doi: 10.3390/insects14040330.
- [16] V. Akanksha, K. Amita, and C. Sarika, "A comparative study of black box testing and white box testing". *International Journal of Computer Sciences and Engineering*, vol. 5, no.12, p. 301-304,2017, doi: 10.26438/ijcse/v5i12.301304.
- [17] H. Nassaji, "Qualitative and descriptive research: data type versus data analysis," *Language Teaching Research*, vol.19, no.2, pp. 129-132, 2015, doi: 10.1177/1362168815572747.
- [18] A. Wan, F. Yang, S. Liu, and W. Feng, "Research on the influence of video games on children's growth in the era of new media", *ICCESSH*, vol. 468, pp. 187-190, 2020, doi: 10.2991/assehr.k.200901.037.
- [19] R. Susan and K. Chinyoka, "Parental attachment on the social and emotional development of children: a case of Mashonaland East Province, Zimbabwe", *IOSR Journal Of Humanities And Social Science*, vol.23, no.5, pp.17-25, 2018.
- [20] J.M. Zosh, C. Gaudrea, R. M. Golinkoff, and K. Hirsh-Pasek, "The power of playful learning in the early childhood setting". *NAEYC*, vol.77, no.2, 2022.