



Development of VHF LC-Passive Filters for Multiband Transient Radio Telescope

Radial Anwar^{a,*}, Mohammad Tariqul Islam^b, Norbahiah Misran^b, Geri Gopir^c

^a School of Applied Science, Telkom University, 40257, Bandung, Indonesia

^b Department of Electrical, Electronic & Systems Engineering, Faculty of Engineering & Built Environment, Universiti Kebangsaan Malaysia, 43600 UKM Bangi, Malaysia

^c School of Applied Physics, Faculty Science & Technology, Universiti Kebangsaan Malaysia, 43600 UKM Bangi, Malaysia

ARTICLE INFO

Received 23 October 2017
Revised 24 November 2017
Accepted 30 November 2017
Available online 07 December 2017

Keywords

Passive LC filters, parasitic, self-resonant frequency, radio telescope

ABSTRACT

Filter is one of key module in a radio telescope system. This article present the development of VHF LC-passive filters meant to support a multiband antenna in a transient radio telescope system by reducing the bandwidth of each operating frequencies. The filters were developed by employing low-cost inductor and capacitor with low self-resonant frequency (SRF) and hence the characteristic are highly affected by the parasitic inductance of the capacitors and parasitic capacitance of the inductors. Therefore, general equation to develop an LC filters was no longer applicable in developing these filters. Nevertheless, three filters were successfully developed, operated at 38 MHz, 74 MHz and 152 MHz with relatively good quality factors up to of about 13.

Acknowledgment

The authors would like to thank Universiti Kebangsaan Malaysia for sponsoring this work.

* Corresponding author at:
School of Applied Science, Telkom University,
Jl. Telekomunikasi No. 1, Terusan Buah Batu, Bandung, 40257
Indonesia.
E-mail address: radialanwar@tass.telkomuniversity.ac.id

ORCID ID:

- First Author: 0000-0002-2022-7195
- Second Author: 0000-0002-4929-3209
- Third Author: 0000-0003-2510-1441

<https://doi.org/10.25124/ijait.v1i02.1077>

Paper_reg_number IJAIT000010211 2017 © The Authors. Published by School of Applied Science, Telkom University.
This is an open access article under the CC BY-NC 4.0 license (<https://creativecommons.org/licenses/by-nc/4.0/>)

1. Introduction

Radio telescope is a device used by the astronomers to observe astronomical objects in radio wavelength. It is similar to radio receiver in communication, comprising antenna, amplifiers, filter, mixer, and detector. In some radio telescope systems, they are also equipped with integrator to enhance the signal to noise ratio. In a radio telescope system, the filter is used to determine the observed frequency. It is also used to control the bandwidth of the receiving system and hence affects the sensitivity of the radio telescope [1]. It is important to set a suitable bandwidth of the filter so that it will not be too narrow and hence degrades the sensitivity of the radio telescope, but also not too wide where the details of the signal's spectrum will be lost due to averaging of the signal intensity within a wide bandwidth.

Capacitor and inductor has been used widely in RF application, including in building a resonant circuit. An inductive-capacitive filter has sharper slopes than a resistive-capacitive filter, thus it is a more effective filter in some applications [2]. Moreover, capacitor and inductor are among components which can easily be found at electronic market. However, inductor and capacitor have limitation especially for high frequency application. As the operating frequency increases, capacitor introduces parasitic inductance [3]-[4], while inductor inherits parasitic capacitance [5]-[7], and the effect is more pronounce as the frequency approaching their self-resonant frequency. Hence, high-frequency applications demand capacitor and inductor with high self-resonant frequencies. For this reason, surface-mount devices are used so often in high frequency circuit design. However, working with surface-mount devices is much more difficult compared to utilizing leaded capacitors and inductors.

In developing filter for high frequency applications, various methods have been proposed. These methods include utilization of microstrip [8]-[10], CMOS [11]-[13] and microelectromechanical technique [14]-[15]. For radio astronomy application, the utilization of High-temperature superconducting (HTS) resonators for filter has been explored in [16]-[19]. However, these methods include complicate designing and manufacturing process.

In this paper, new VHF LC-Passive filters are proposed. The filters are developed by utilizing inexpensive components, comprising ceramic capacitors, carbon inductors and coil inductor, which are theoretically inherit low self-resonance frequency relative to the operating frequency range (VHF band). Nevertheless, measurement result shows that these filters are able to operate in the designated frequencies. These filters are developed to be employed in a multiband transient radio telescope array system. Passive filter concept is chosen to avoid additional significant noises in the radio telescope system, generated by its own subsystem components.

2. Filter Architectures

In VHF region, the assigned frequency bands by ITU for astronomical purposes are 37.5 MHz–38.25 MHz, 73.0 MHz–74.6 MHz and 150.05 MHz–153.0 MHz [20]. Therefore, the filters are designed to operate within these frequencies. The filters are adopting the LC circuit method, utilizing low-cost components comprising ceramic capacitors, carbon inductors and coil inductor. These components inherit low self-resonant frequency (SRF). Hence, simulation did not provide a good match between theoretical calculation and the implemented circuit. The final schematics are obtained from series of tuning process with the real components.

The schematic of the first filter is shown in Figure 1. It comprises a band-pass filter and a low-pass filter. The low-pass filter is needed to suppress the harmonic resonances which occur in of the band-pass filter respond, covering the 74 MHz and 151 MHz bands. A male to male sma connector is utilized as a "bridge" to connect the band-pass section with the low-past section. The idea is to terminate the band-pass section at 50 ohms resistance and to start the low-pass section also at 50 ohms resistance. Hence, both circuits are not interfering one to another and works independently.

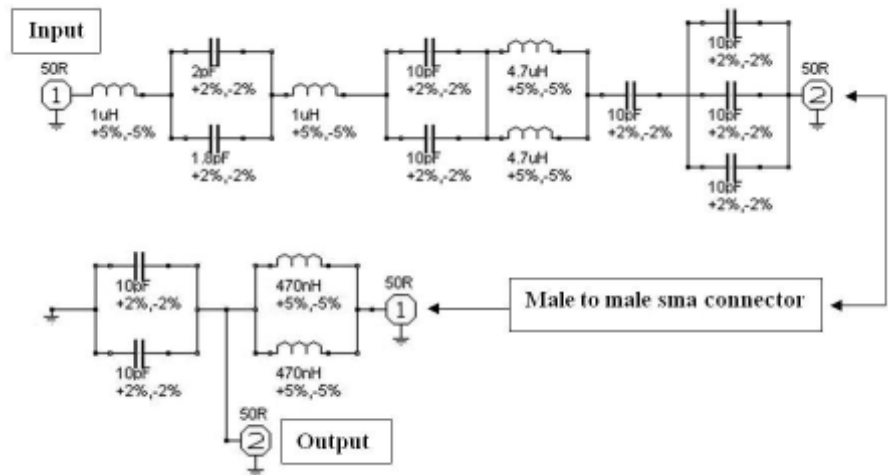

Figure 1 Schematic of The First Filter

The second filter is designed to operate at 74 MHz. Differ to the first filter, the harmonic resonances of the second filter are occurring far from the operating frequencies of the antenna (around 540 MHz and 1 GHz), and hence low-pass filter is not needed. Figure 2 shows the schematic of the second filter.

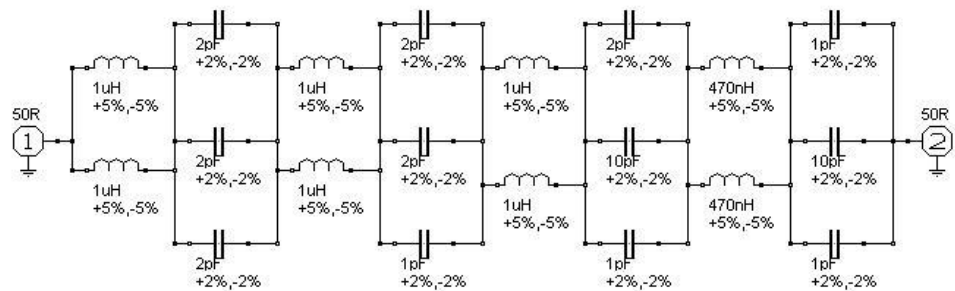

Figure 2 Schematic of The Second Filter

The third filter is designed to operate at 152 MHz. Similar to the second filter, low-pass filter is not needed as the harmonic resonances of the second filter are occurring in frequencies much higher than the operating frequencies of the antenna. Schematic of the third filter is depicted in Figure 3.

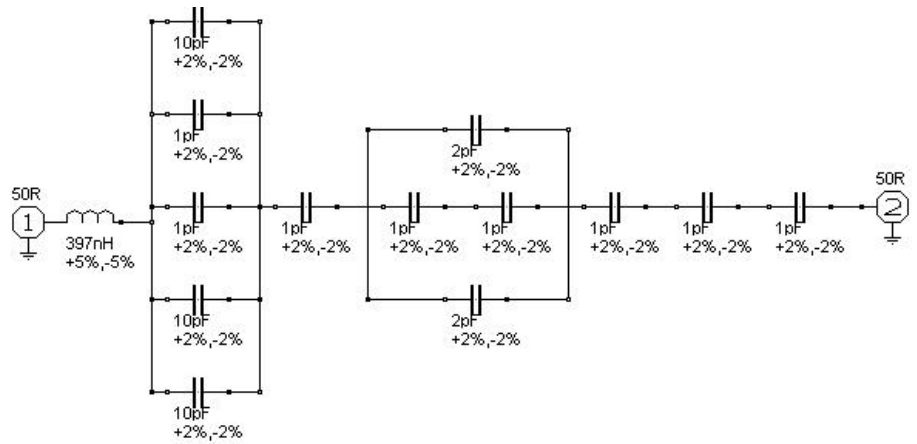

Figure 3 Schematic of the third filter

3. Result and Discussion

Three filters are developed to support the performance of the antenna in mitigating the Radio Frequency Interferences (RFI). They are developed to operate within the protected frequency bands with relatively narrow bandwidth (less than 20%). The first filter has the peak frequency at 37.9 MHz with bandwidth of about 2.9 MHz. Insertion loss of about 4.6 dB was introduced by the filter which determined from measurement. Ceramic capacitors and carbon inductors are utilized in this circuit. The constructed first filter and its respond are depicted in Figure 4 and 5 respectively.

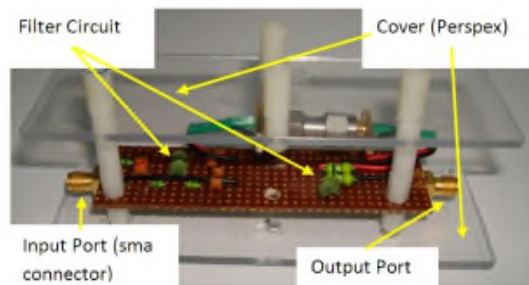

Figure 4 The Constructed First Filter

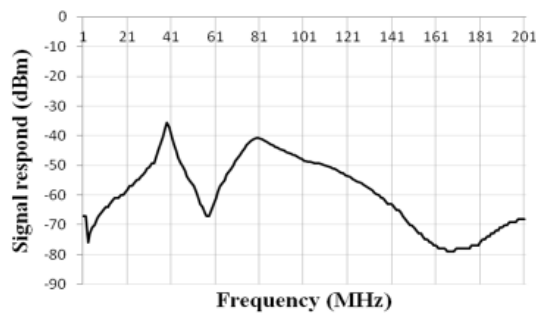

Figure 5 Respond Of The First Filter

The second filter is operated at 74 MHz with bandwidth of about 14 MHz and insertion loss of about 5.7 dB. It is also utilizing ceramic capacitors and carbon inductors. Figure 6 and Figure 7 shows the constructed circuit and its respond respectively.

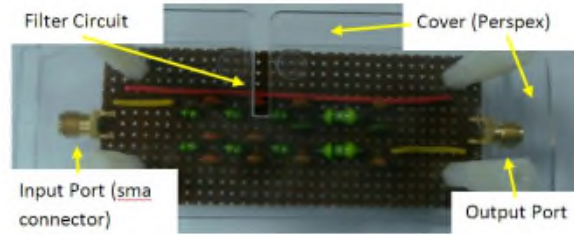

Figure 6 The Constructed Second Filter

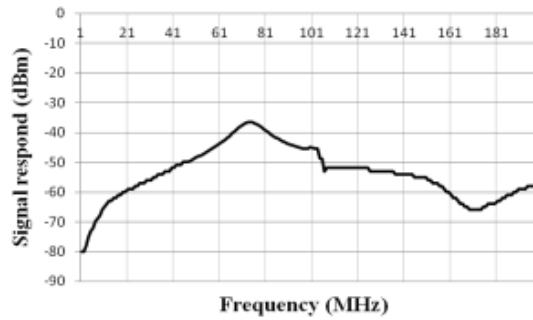

Figure 7 Respond of The Second Filter

The third filter operates at 152.1 MHz with bandwidth of about 16.9 MHz and insertion loss of about 5.5 dB. Since the frequency is already very high, carbon capacitors are no longer able to reach the peak of the filter at the designed frequency. Hence, a coil inductor is employed in this circuit. The constructed third filter and its respond are shown in Figure 8 and Figure 9 respectively.

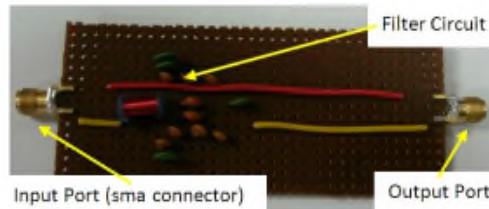

Figure 8 The Constructed Third Filter

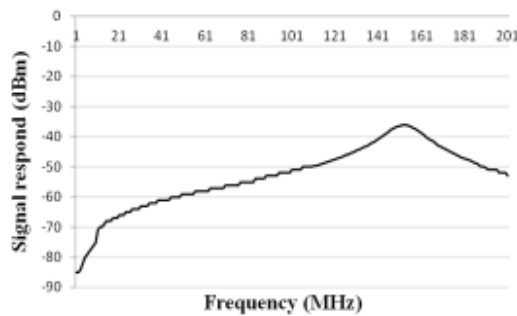

Figure 9 Respond of The Third Filter

These filters have been utilized to support the performance of a multiband antenna presented in [21] and [22], meant for transient VHF radio telescope system. There are some characteristic that should be addressed regarding this work. At high frequencies, the behavior of inductor is very different from their low frequency behavior [23]. The parasitic capacitances and resistances are distributed parameters which are negligible at low frequency but play a role of increasing significance as

the operating frequency increases. The values of these parasitic capacitances and resistances are change based on the operating frequency. The inductance itself is not constant when the frequency changes. Therefore, the theoretical prediction of the frequency responds of an inductor is a difficult task, as the operating frequencies are also considerably high (VHF region).

Another thing which also should be noticed is the capacitors characteristic. At higher operating frequency, a capacitor has more pronounce inductive characteristic. The ceramic disk capacitors used in the traps and filters circuits have low SRF and commonly used in circuit which operates in kilohertz frequency. Therefore, using the ceramic disk capacitor in VHF circuits leads to differences between its theoretical and actual characteristic.

4. Conclusion

Design and performance of three narrowband VHF passive filters are presented in this paper. The filters are developed by employing low-cost components with simple inductor-capacitor structures. This works have shown that low cost inductor and capacitor still can be utilized to develop filters which are operated near the component's SRF. Measurement result shows that the filters are suitable to be employed in VHF radio telescope system which operates at the protected frequencies by ITU for radio astronomy observation.

Bibliography

- [1] W. N. Christiansen and J. A. Högbom, Radiotelescopes 2nd Edn.. Cambridge: Cambridge University Press., 1985, Ch. 1.
- [2] R. Mancini, "Understanding Basic Analog – Passive Devices", Texas Instruments Application Report SLOA 027, 1999.
- [3] R. Fiore, "Capacitors in Broadband Applications", American Technical Ceramics Technical Notes, 2001.
- [4] J. Cain, "Parasitic Inductance of Multilayer Ceramic Capacitors", AVX Corporation Technical information, 2004.
- [5] A. Massarini and M. K. Kazimierczuk, "Self-Capacitance of Inductors", *IEEE Trans. on Power Electronics*, vol. 12, no. 4, pp. 671-676, 1997.
- [6] G. Zulauf, W. Liang and J. Rivas-Davila, "A unified model for high-power, air-core toroidal PCB inductors," in *2017 IEEE 18th Workshop on Control and Modeling for Power Electronics (COMPEL)*, pp. 1-8, Jul. 2017.
- [7] C.M. de Miranda and S.F. Pichorim, "A Self-Resonant Two-Coil Wireless Power Transfer System Using Open Bifilar Coils," *IEEE Transactions On Circuits And Systems-II: Express Briefs*, vol. 64, no. 6, pp. 615-619, June 2017
- [8] W. Chen, X. Guo, B. Cao, X Zhang, B. Wei, Y. Zhang and X. Lu, "A Superconducting Microstrip Ultra-Wideband (UWB) Bandpass Filter at VHF-Band", *IEEE Microwave and Wireless Components Letters*, vol. 19, no. 10, pp. 635-637, 2009.
- [9] W. P. Wong and I. C. Hunter, "Electronically Reconfigurable Microwave Bandpass Filter", *IEEE Trans. on Microwave Theory and Techniques*, vol. 57, no. 12, pp. 3070-3079, 2009.
- [10] L. Zhang, Z.-Y. Yu and S.-G. Mo, "Novel Planar Multimode Bandpass Filters with Radial-Line Stubs", *Progress In Electromagnetics Research, PIER 101*, pp. 33-42, 2010.
- [11] X. Shou and M. A. Green, "Programmable VHF CMOS Read-channel Continuous-time Filter with On-chip Tuning", *Proc. of The 2001 IEEE International Symposium on Circuits and Systems*, Sydney, NSW, Australia, 6-9 May 2001, pp. I-208 - I-211.
- [12] J. Silva-Martínez, J. Adut, J. M. Rocha-Perez, M. Robinson and S. Rokhsaz, "A 60-mW 200-MHz Continuous-Time Seventh-Order Linear Phase Filter With On-Chip Automatic Tuning System", *IEEE Journal of Solid-state Circuits*, vol. 38, no. 2, pp. 216-225, 2003.
- [13] V. Saari, M. Kaltiokallio, S. Lindfors, J. Ryyänen and K. A. I. Halonen, "A 240-MHz Low-Pass Filter With Variable Gain in 65-nm CMOS for a UWB Radio

- Receiver”, *IEEE Trans. on Circuits and Systems-I: Regular Papers*, vol. 56, no.7, pp. 1488-1499, 2009.
- [14] F. D. Bannon, J. R. Clark and C. T.-C. Nguyen, “High-Q HF Microelectromechanical Filters”, *IEEE Journal of Solid-state Circuits*, vol. 35, no. 4, pp. 512-526, 2000.
- [15] C.-L. Dai, M.-C. Chiang and M. W. Chang, “Simulation and Fabrication of HF Microelectromechanical Bandpass Filter”, *Microelectronics Journal*, vol. 38, pp. 828–833, 2007.
- [16] Y. Li and M. J. Lancaster, “Fifteen Pole Superconducting Filter for Radio Astronomy”, *Proc. of 6th IEEE High Frequency Postgraduate Student Colloquium*, Cardiff, UK, 9-10 Sept. 2001, pp. 47-52, 2001.
- [17] J. Zhou, M. J. Lancaster, F. Huang, N. Roddis and D. Glynn, “HTS Narrow Band Filters at UHF Band for Radio Astronomy Applications”, *IEEE Trans. on Applied Superconductivity*, vol. 15, no. 2, pp. 1004-1007, 2005.
- [18] T. Yu, C. Li, F. Li, Q. Zhang, L. Sun, L. Gao, Y. Wang, X. Zhang, H. Li, C. Jin, J. Li, H. Liu, C. Gao, J. Meng and Y. He, “A Wideband Superconducting Filter Using Strong Coupling Resonators for Radio Astronomy Observatory”, *IEEE Trans. on Microwave Theory and Techniques*, vol. 57, no. 7, pp. 1783-1789, 2009.
- [19] A. Corona-Chavez, I. Llamas-Garro and M. J. Lancaster, “A High Temperature Superconducting Quasi-Elliptic Notch Filter for Radioastronomy”, *Microwave and Optical Technology Letters*, vol. 52, no. 1, pp. 88-90, 2010.
- [20] CRAF Handbook for Radio Astronomy, 3rd Edn., Committee on Radio astronomy Frequencies (CRAF), European Science Foundation, 2005.
- [21] R. Anwar, N. Misran, M. T. Islam, and G. Gopir, “Compact multiband VHF antenna for transient radio telescope,” *Proc. of the 2009 International Conference on Space Science and Communication*, pp. IS09_035, 2009.
- [22] R. Anwar, N. Misran, M. T. Islam, and G. Gopir, “Multiband antenna for low-frequency radio telescope,” *WSEAS Transactions on Communications*, vol. 8, pp. 755-764, August 2009.
- [23] A. Massarini, M. K. Kazimierczuk and G. Grandi, “Lumped parameter models for single- and multiple-layer inductors”, *Proc. Power Electronics Specialists Conference*, PESC 1, pp. 295–301, 1996.