

ON THE DESIGN OF BCH CODES POLYNOMIALS FOR DIGITAL TELEVISION DVB-T2 BROADCASTING SYSTEMS

Hilman Auzan Mulyono¹, Khoirul Anwar², and Budi Prasetya³

^{1,2}*The Center for Advanced Intelligent Communications (AICOMS)*

^{1,2,3}*School of Electrical Engineering, Telkom University*

*{hilmanauz@student., anwarkhoirul@, budiprasetya@}telkomuniversity.ac.id

Manuscript received 16 May 2020; revised 19 June 2020; accepted 25 June 2020

Abstract

Digital Video Broadcasting Terrestrial–Second Generation (DVB-T2) requires a high coding rate to transmit data of high-quality video. This paper evaluates Bose-Chaudhuri-Hocquenghem (BCH) codes for the DVB-T2 to measure the gain of BCH codes. This paper evaluates the BCH codes as outer coding to be combined with other different inner encoding schemes such as Low Density Parity Check (LDPC) codes and convolutional codes to measure the best suitable inner encoding scheme. This paper also studies the performances of BCH codes for DVB-T2 specified by two different standards, i.e., (a) The European Telecommunications Standards Institute (ETSI) Technical Specification (TS) 102 831 and (b) ETSI European Standard (EN) 302 755. To obtain better error correcting capability, we propose new BCH polynomials based on the general guideline from ETSI TS 102 831 for Galois Field $GF(2^{14})$. We perform computer simulations to evaluate bit-error-rate (BER) performances under additive white Gaussian noise (AWGN) channel and Indonesia DVB-T2 channel model. We revealed the superiority of BCH codes in high data rate transmission, which is required for DVB-T2, and found that BCH codes are better suited to the LDPC codes as inner encoding rather than to the convolutional codes. We also confirmed that BCH codes of DVB-T2 from ETSI TS 102 831 using the proposed BCH polynomials have better performances compared to the standard polynomial of ETSI EN 302 755. We are expecting that the obtained polynomials can be adopted by the BCH codes of Indonesia DVB-T2 system. These results are expected to support the Indonesian government in determining the parameters of the BCH codes of DVB-T2 for Indonesia.

Keywords: BCH codes; Generator polynomial; DVB-T2; FEC Encoding; Broadcasting System.

DOI: 10.25124/jmeecs.v6i1.2828

1. Introduction

Indonesia has been using analog television transmitters for more than 60 years which has worked well. However, this technology has now turned into a digital television transmitter. In 2007, Indonesia used the Digital video broadcasting terrestrial (DVB-T) digital television standard [1]. The rapid development of digital television in the world has made Indonesia chooses to

change from DVB-T to Digital video broadcasting terrestrial–second generation (DVB-T2) owned by the European Telecommunications Standards Institute (ETSI) since 2012 [2]. The DVB-T2 standard was developed to have 60% higher data rate. To realize it, DVB-T2 can use up to 256 quadrature amplitude modulation (QAM) with 32K fast fourier transform (FFT) size, rotated constellation, Cyclic Prefix–Orthogonal Frequen-

cies Division Multiplexing (CP-OFDM), and new system of Forward Error Correction (FEC). Based on [3], DVB-T2 in Indonesia uses tuning frequency of 478–694 MHz, channel bandwidth of 8 MHz, modulation of QPSK–256 QAM, FFT size of 1K–32K, and TV stations of 22–48 units.

Research in [4] proposes FEC encoding using Low-Density Parity Check (LDPC) codes with Bit-Interleaved Coded Modulation (BICM) schemes. However, this paper uses FEC encoding with a combination of 2 types of coding, i.e., outer coding and inner coding [5]. This paper focuses on the outer coding of FEC encoding DVB-T2. High coding rate is used for outer coding of DVB-T2 to transmits data for high-quality video without jitter [6]. Standard of DVB-T2 uses Bose, Chaudhuri, Hocquenghem (BCH) codes as outer coding of FEC encoding [6].

ETSI publishes several types of standards for DVB-T2 including the European Standard (EN) and Technical Specification (TS). Between the two types of standards, We found that the specification of BCH codes from TS is completely different from EN. In TS 102 831 [7], BCH polynomials are generated based on $GF(2^{14})$ with error correction capability $t = 12$ for short FECFRAME. However, in EN 302 755 [6], BCH polynomials have been provided to be a generator polynomial of BCH codes DVB-T2.

In this paper, we study the structure of BCH codes of DVB-T2 for Indonesia including the coding gain of BCH codes as the outer coding of DVB-T2. We directly study BCH codes polynomials on the TS and EN standards of DVB-T2 technology. We also evaluate the suitable inner coding DVB-T2 pairing with the BCH codes.

To have a better performance of digital Television in Indonesia, we propose BCH codes polynomials based on the general guideline on TS. Our contributions are summarized as follows:

1. BCH polynomials for $GF(2^{14})$ are proposed to provide better performance with higher coding gain.
2. BER performances of DVB-T2 outer coding are investigated.
3. BER performances of DVB-T2 total coding constructed from inner and outer coding schemes are evaluated.
4. BER performances of DVB-T2 BCH codes under Indonesia digital TV channel model are evaluated.

The rest of this paper is organized as follows. Section 2 discusses the system model of DVB-T2.

In Section 3, we propose BCH polynomials for BCH codes DVB-T2. Performances are evaluated and analysed in Section 4. Finally, the conclusions are provided in Section 5 with some concluding remarks.

2. System Model of DVB-T2

Fig. 1 shows the system model of communication systems in DVB-T2. BCH codes are used as outer coding of FEC encoding. We consider DVB-T2 modulation using Quadrature Phase Shift Keying (QPSK) and multipath fading channel model based on Bandung DVB-T2 channel model used in [8]. We also consider Orthogonal Frequency Division Multiplexing (OFDM) based on the DVB-T2 standard.

In Fig. 1, the bit stream b is generated randomly for the number of bits of information k_{BCH} . We encode bits b by multiplying $x^{N_{BCH}-k_{BCH}}$ to generate the message polynomial $m(x)$. In the construction of BCH codes, $g(x)$ block form a polynomial generator. The quotient of $m(x)$ divided by the polynomial generator $g(x)$ is used to be parity check bits. Adding the polynomial message $m(x)$ to parity check bits produces the codeword $C_{BCH} = (C_1, C_2, \dots, C_N)$, where N is blocklength of DVB-T2 BCH codes. Then, C_{BCH} encoded with inner encoder to obtained codeword from FEC encoding.

Codeword of FEC encoding C_{inner} is mapped and modulated into modulator M to produce \mathbf{x}_m symbol. The Inverse Fast Fourier Transform (IFFT) FH with 4096 FFT-size is used to transform x_m to symbol x . The block "CP" adds cyclic prefix (CP) in x with length equal to the number of paths. OFDM symbols x_{cp} are transmitted through multipath channel H . At the receiver, a noise \mathbf{n} is added and The received signal y_{cp} can be expressed as

$$\mathbf{y}_{cp} = h \cdot \mathbf{x}_{cp} + \mathbf{n}, \quad (1)$$

where the received signal \mathbf{y}_{cp} is corrupted by noise \mathbf{n} , which is modeled by Gaussian distribution. CP in \mathbf{y}_{cp} is removed in CP Removal block to generate \mathbf{y} . The Fast Fourier Transform (FFT) is conducted in F block to generate y_e ; the y_e is then equalized in EQ block using mean minimizes squared error (MMSE) [9] to become \mathbf{y}_m ; the \mathbf{y}_m is then demodulated by \mathbf{M}^{-1} block into expected codeword \hat{C}_{inner} from FEC decoding. Inner decoder will obtained \hat{C}_{BCH} to be decoded by BCH decoder. In the BCH decoder block, \hat{C}_{BCH} can be used to calculate the syndrome. Furthermore, the value of the syndrome is used to determine the location of the error polynomial $\sigma(y)$ and can also find the error position α^i . Delay is used to

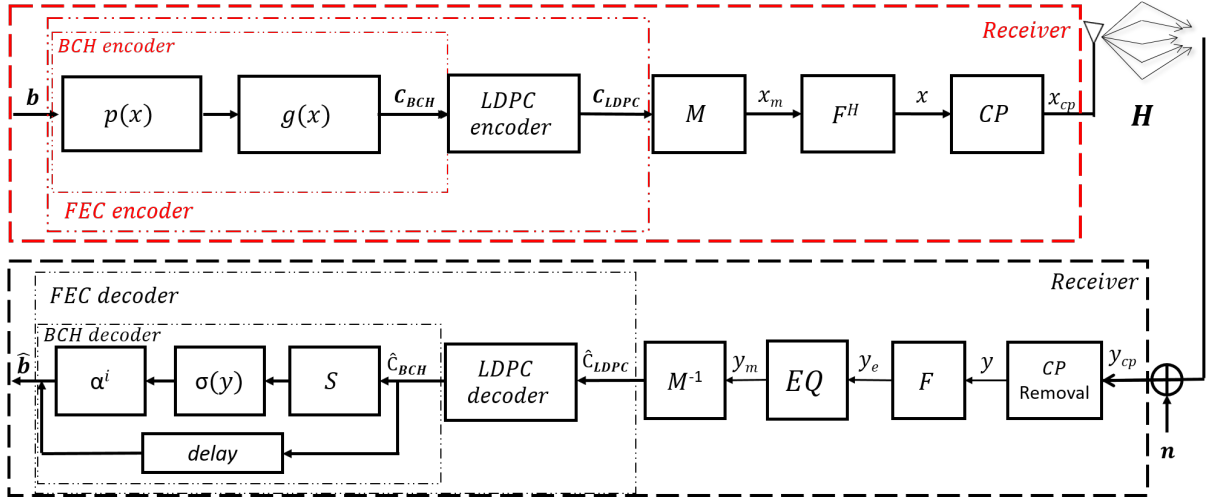

Fig. 1. System model of DVB-T2 System.

compensate for the delay in utilization. From BCH decoder obtained bit source \hat{b} .

In this paper, we compare the \hat{b} in the receiver with b to obtain BER performances of DVB-T2 system. The theoretical BER in Rayleigh fading channels with QPSK modulation is expressed as [10]

$$P_{bQPSK-Fading} = \frac{1}{2} \left[1 - \frac{1}{\sqrt{1 + \frac{1}{\frac{E_b}{N_0}}}} \right], \quad (2)$$

where $\frac{E_b}{N_0}$ is the energy bit per noise spectral density, of which the signal-to-noise power ratio (SNR) for QPSK is defined as

$$\gamma = 2 \cdot R \cdot \frac{E_b}{N_0} \quad (3)$$

with R being the channel coding rate.

3. The Proposed BCH Polynomials for BCH Codes DVB-T2

The proposed BCH polynomials is shown in Table 1, where the polynomials are generated from $GF(2^{14})$ [7]. Elements for $GF(2^{14})$ are expressed with α as the polynomial

$$\alpha^i \Rightarrow x^i \text{ mod } \varphi(x)|_{x=\alpha}, \quad (4)$$

where $\varphi(x)$ is primitive polynomial. We use primitive polynomial of $GF(2^{14})$ is [11]

$$\varphi(x) = 1 + x + x^6 + x^{10} + x^{14}. \quad (5)$$

Let $\mathcal{O}(x)$ be an irreducible polynomial over $GF(2^m)$. If $\mathcal{O}(x)$ has β as its root, where β is an

Table 1: The proposed BCH Polynomials of $GF(2^{14})$ for short FECFRAME $N_{inner} = 16200$.

$g_1(x)$	$1 + x^4 + x^8 + x^{13} + x^{14}$
$g_2(x)$	$1 + x^6 + x^8 + x^9 + x^{12} + x^{13} + x^{14}$
$g_3(x)$	$1 + x^4 + x^5 + x^7 + x^8 + x^{10} + x^{14}$
$g_4(x)$	$1 + x^2 + x^5 + x^6 + x^7 + x^8 + x^9 + x^{10} + x^{14}$
$g_5(x)$	$1 + x^2 + x^3 + x^9 + x^{11} + x^{12} + x^{14}$
$g_6(x)$	$1 + x^6 + x^8 + x^{13} + x^{14}$
$g_7(x)$	$1 + x + x^2 + x^3 + x^4 + x^5 + x^8 + x^9 + x^{12} + x^{14}$
$g_8(x)$	$1 + x^3 + x^4 + x^5 + x^6 + x^7 + x^9 + x^{12} + x^{14}$
$g_9(x)$	$1 + x + x^4 + x^6 + x^7 + x^9 + x^{10} + x^{11} + x^{12} + x^{13} + x^{14}$
$g_{10}(x)$	$1 + x^3 + x^8 + x^{13} + x^{14}$
$g_{11}(x)$	$1 + x^3 + x^4 + x^6 + x^{10} + x^{12} + x^{14}$
$g_{12}(x)$	$1 + x^3 + x^5 + x^8 + x^9 + x^{12} + x^{14}$

element in $GF(2^{14})$, then $\mathcal{O}(x)$ is the minimum polynomial of β . The minimum polynomial of β can be obtained as

$$\mathcal{O}(x) = \prod_{i=0}^{L-1} (x - \beta^{2^i}), \quad (6)$$

where L is the smallest integer such that $\beta^{2^L} = \beta$. The generator polynomial of a BCH codes DVB-T2 is the least common multiple (LCM) of the minimum polynomials of $\mathcal{O}(x)$ [12].

$$g(X) = \text{LCM}[\mathcal{O}_1(x), \mathcal{O}_2(x), \dots, \mathcal{O}_t(x)], \quad (7)$$

where $\mathcal{O}_i(x)$ represents the BCH polynomials of each $g_t(x)$ with $t = 1, 2, \dots, 12$.

BCH codes of DVB-T2 encodes information bits into a codeword [6] with the following steps:

1. Multiply the information bit M

$$M = M_{K_{bch}-1}x^{k_{bch}-1} + M_{K_{bch}-2}x^{k_{bch}-2} + \dots + M_1x + M_0, \quad (8)$$

by the generator polynomial $g(x) = x^{N_{bch}-K_{bch}}$.

2. Divide M by $g(x)$ to produce the remainder of the division $d(x)$ as

$$d(x) = d_{N_{bch}-K_{bch}-1}x^{N_{bch}-K_{bch}-1} + \dots + d_1x + d_0. \quad (9)$$

3. Construct codeword $c(x)$ to be output for the BCH encoder as

$$c(x) = x^{N_{bch}-K_{bch}}m(x) + d(x). \quad (10)$$

4. Performance Evaluations

In this section, we verify the BER performances of DVB-T2 BCH codes, DVB-T2 FEC encoding, and BCH polynomials in AWGN channel. We also verify BER performances of DVB-T2 BCH codes using the proposed BCH polynomials in Bandung DVB-T2 channel model. We analyze the BER performances using computer-based simulation. BER performance is measured by taking the ratio between the number of bit serror at the receiver side and the number of bits have been transmitted and is defined as

$$P_b = \frac{u}{(k \times f)} \quad (11)$$

where u is total error bits, k is number of bits transmitted, and f is the frame of each trial.

4.1 BER Performances of DVB-T2 BCH codes

This section evaluates the BER performances of DVB-T2 outer coding using BCH codes compared with punctured convolutional codes. Fig. 2 shows that the red box is a deleted bits derived from coding rate $R = 1/2$ convolutional codes [13, 14] with constraint length $K = 2$ and generator $G = ([1], [10])$. Fig. 3 shows the BER performances of DVB-T2 outer coding in AWGN channel with length of information $k = 7032$ and blocklength $N = 7200$. The horizontal axis is the SNR γ , while the vertical axis is the BER P_b . The BER performances of 10^{-4} is obtained by BCH codes at $\gamma = 9.7$ dB while convolutional codes at $\gamma = 11.45$ dB. BCH codes have better performances with coding gain $\gamma_c = 1.75$ dB compared to the convolutional codes.

4.2 BER Performances of DVB-T2 FEC encoding

We have simulated the BER performance of FEC encoding with BCH codes as outer coding followed by the different inner coding schemes such as LDPC codes and convolutional codes in AWGN channel. Fig. 4 shows the BER performances of DVB-T2 FEC encoding with coding

Table 2: BCH Polynomials of ETSI EN 302 755 for short FECFRAME $N_{inner} = 16200$.

$g_1(x)$	$1 + x + x^3 + x^5 + x^{14}$
$g_2(x)$	$1 + x^6 + x^8 + x^{11} + x^{14}$
$g_3(x)$	$1 + x + x^2 + x^6 + x^9 + x^{10} + x^{14}$
$g_4(x)$	$1 + x^4 + x^7 + x^8 + x^{10} + x^{12} + x^{14}$
$g_5(x)$	$1 + x^2 + x^4 + x^6 + x^8 + x^9 + x^{11} + x^{13} + x^{14}$
$g_6(x)$	$1 + x^3x^7 + x^8 + x^9 + x^{13} + x^{14}$
$g_7(x)$	$1 + x^2 + x^5 + x^6 + x^7 + x^{10} + x^{11} + x^{13} + x^{14}$
$g_8(x)$	$1 + x^5 + x^8 + x^9 + x^{10} + x^{11} + x^{14}$
$g_9(x)$	$1 + x + x^2 + x^3 + x^9 + x^{10} + x^{14}$
$g_{10}(x)$	$1 + x^3 + x^6 + x^9 + x^{11} + x^{12} + x^{14}$
$g_{11}(x)$	$1 + x^4 + x^{11} + x^{12} + x^{14}$
$g_{12}(x)$	$1 + x + x^2 + x^3 + x^5 + x^6 + x^7 + x^8 + x^{10} + x^{13} + x^{14}$

rate of outer coding $R_{outer} = 7032/7200$, coding rate of inner coding $R_{inner} = 1/2$. The horizontal axis is the SNR γ , while the vertical axis is the BER P_b . The BER performances of 10^{-4} is achieved by LDPC codes at $\gamma = 1.65$ dB, by BCH + LDPC codes at $\gamma = 0.8$ dB, by convolutional codes at $\gamma = 4.4$ dB, and by BCH + convolutional codes at $\gamma = 4$ dB.

These results indicate that BCH codes can improve the performance of LDPC codes by achieving a coding gain of 0.85 dB, while convolutional codes only provide a coding gain of 0.4 dB. BCH + LDPC codes at BER at 10^{-4} have a gap from the Shannon limit of 1.8 dB, where BCH + convolutional codes have a gap of 3.9 dB from the Shannon limit. LDPC codes produce a turbo cliff at $\gamma = 0.5$ dB because of the matching between the extrinsic information transfer (EXIT) curves of the variable node and check node [15]. The BCH codes and LDPC codes as outer and inner coding, respectively, provide the best performance because BCH codes can achieve the highest coding gain leading to a performance of both having a gap to Shannon limit below 3 dB.

4.3 BER Performances of BCH polynomials

We evaluate the BER performances of BCH codes using the proposed BCH polynomials from ETSI TS 102 831 compared to BCH polynomials from ETSI EN 302 755 shown at Table 2. Fig. 5 shows that the BER performances of 10^{-4} is achieved by BCH polynomials with ETSI EN 302 755 at $\gamma = 11.35$ dB and by ETSI TS 102 831 at $\gamma = 9.7$ dB. The BER performances of BCH codes using the proposed BCH polynomials have good performances with an improvement of 1.75 dB better than the BCH polynomials of ETSI EN 302 755.

We also evaluate the BER performances of DVB-T2 BCH codes using the proposed BCH

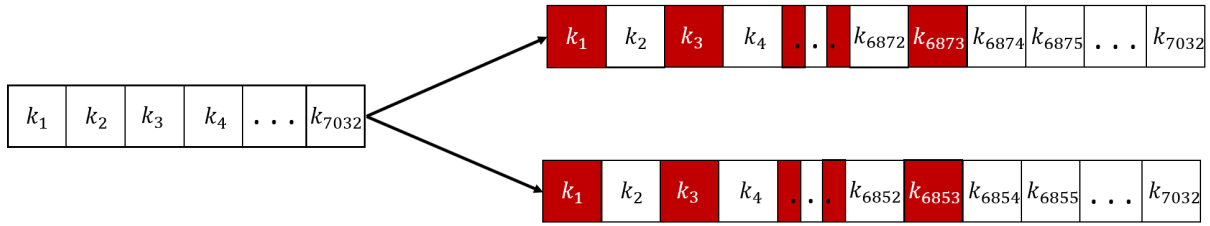

Fig. 2. Block structure of convolutional codes with rate $R = 7032/14064$ to be punctured to obtain new rate $R = 7032/7200$.

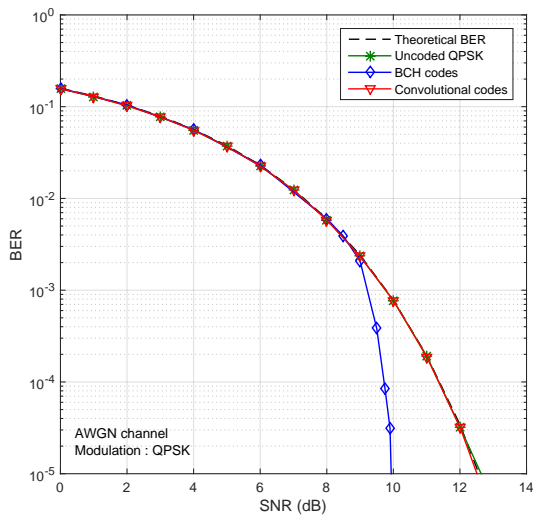

Fig. 3. BER performances of BCH codes compared to that of the convolutional codes with $N_{outer} = 7200$ in AWGN channel.

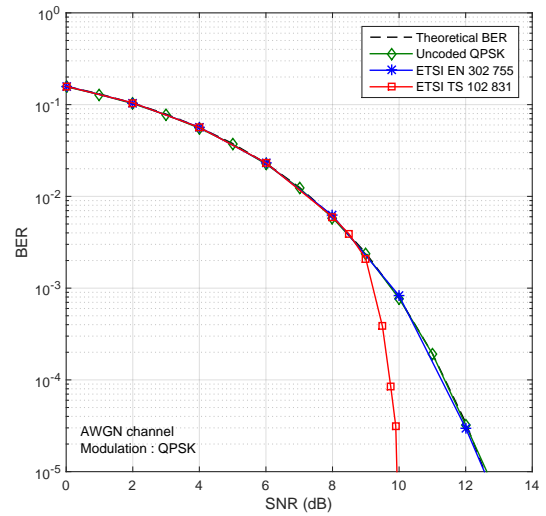

Fig. 5. BER performances of BCH codes with the proposed polynomials with $N_{outer} = 7200$ in AWGN channel.

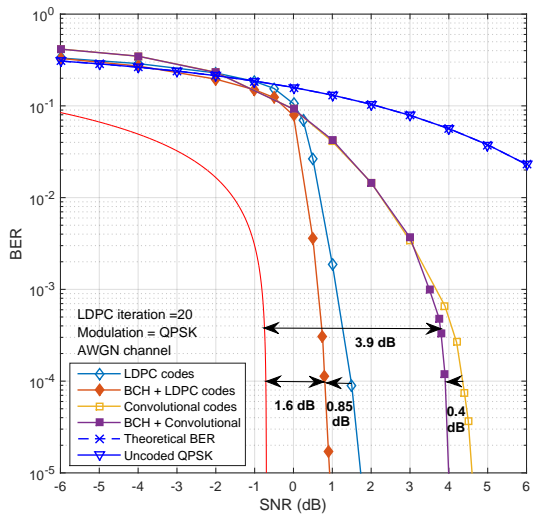

Fig. 4. BER performance of 2 inner coding schemes, i.e., BCH+LDPC codes and BCH+convolutional codes with $N_{inner} = 16200$ in AWGN channel.

polynomials, of which the result is expected to be used as a reference for DVB-T2 system implementation, especially for outer coding of DVB-T2 in Indonesia.

Fig. 6 shows the BER performances of OFDM with CP length 8 and FFT size of 4096 under Bandung DVB-T2 channel model [8]. The horizontal axis is the average SNR γ , while the vertical axis is the average BER. The theoretical BER of uncoded Rayleigh fading is shown as the baseline comparison. We found that the BER performances of uncoded DVB-T2 has better performance than the uncoded theoretical Rayleigh fading with QPSK modulation caused by the multipath fading gain captured by the OFDM system. The BER performances of 10^{-3} is achieved by DVB-T2 BCH codes with $N_{outer} = 7200$ at $\gamma = 25.2$ dB with an improvement, which is expected to be significant at higher SNR due to the high channel coding rate.

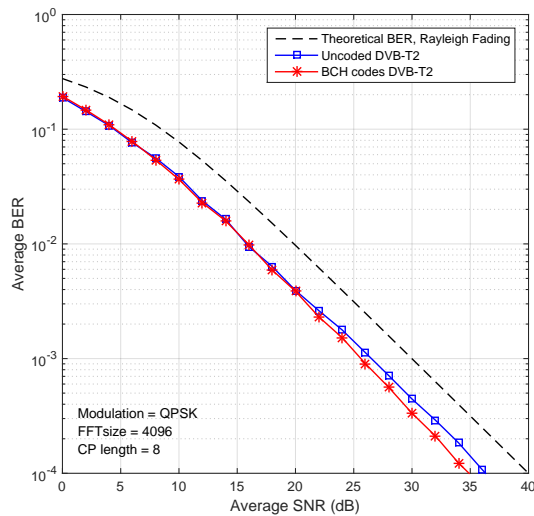

Fig. 6. BER performances BCH codes under the Indonesia digital TV channel model.

5. Conclusion

We have studied several aspects of BCH codes, e.g., polynomials and coding gain, of DVB-T2 systems. We performed computer simulations to evaluate BCH codes and found that the BCH codes have better performance than convolutional codes as outer coding scheme of DVB-T2 with a coding gain of 1.75 dB. We also evaluated the contribution of BCH codes as outer coding and paired with inner coding schemes of LDPC codes and convolutional codes constructing BCH+LDPC codes and BCH+convolutional codes, respectively. BCH+LDPC codes have better performances than BCH+convolutional codes because LDPC codes are capable of producing turbo cliffs performances resulted from the matching between the extrinsic information transfer curve of variable node and check node.

This paper has also proposed new BCH polynomials generated from $GF(2^{14})$ for DVB-T2 BCH codes, where we have confirmed that The proposed BCH polynomials have better performances compared to polynomials of ETSI EN 302 755. The proposed BCH polynomials are different compared to polynomial of ETSI EN 302 755 in every degree. This paper also evaluated the performances of DVB-T2 BCH codes under the Indonesian digital TV channel model to estimate the performances in Indonesia. The results of this paper are expected to provide contributions to the development and implementation of Indonesia digital TV.

References

- [1] Menteri Komunikasi dan Informatika, "Peraturan menteri komunikasi dan informatika nomor: 07/p/m.kominfo/3/2007," 2007.
- [2] —, "Peraturan menteri komunikasi dan informatika nomor:05/per/m.kominfo/2/2012," 2012.
- [3] —, "Persyaratan teknis alat dan/atau perangkat penerima televisi siaran digital berbasis standar digital video broadcasting terrestrial-second generation," 2018.
- [4] M. Li, C. A. Nour, C. Jgo, and C. Douillard, "Design and FPGA prototyping of a bit-interleaved coded modulation receiver for the DVB-T2 standard," in *2010 IEEE Workshop On Signal Processing Systems*, 2010, pp. 162–167.
- [5] W. Fischer, *Digital Video and Audio Broadcasting Technology: A Practical Engineering Guide*, 3rd ed. Springer Publishing Company, Incorporated, 2010.
- [6] ETSI, "Digital video broadcasting (DVB); frame structure channel coding and modulation for a second generation digital terrestrial television broadcasting system (DVB-T2)," ETSI, Tech. Rep., 7 2015.
- [7] —, "Digital video broadcasting (DVB); implementation guidelines for a second generation digital terrestrial television broadcasting system (DVB-T2)," ETSI, Tech. Rep., 8 2012.
- [8] D. Fitriyani, K. Anwar, and D. M. Saputri, "Study on radio frequency profile of Indonesia digital television DVB-T2 for urban areas," in *International Conference on Islam, Science, and Technology (ICONISTECH)*, Bandung, Indonesia, March 2019.
- [9] Proakis, *Digital Communications 5th Edition*. McGraw Hill, 2007.
- [10] H. Harada and R. Prasad, *Simulation and Software Radio for Mobile Communications*. USA: Artech House, Inc., 2002.
- [11] Y. Jiang, *A Practical Guide to Error-Control Coding Using MATLAB*, P. McCarthy, Ed. 685 Canton Street Norwood, MA 02062: Artech House, September 2010.
- [12] S. B. Wicker, *Error Control Systems for Digital Communication and Storage*. USA: Prentice-Hall, Inc., 1994.

- [13] D. Haccoun and G. Bégin, "High-rate punctured convolutional codes for viterbi and sequential decoding," *IEEE Trans. Communications*, vol. 37, pp. 1113–1125, 1989.
- [14] Y. Yasuda, K. Kashiki, and Y. Hirata, "High-rate punctured convolutional codes for soft decision viterbi decoding," *IEEE Transactions on Communications*, vol. 32, no. 3, pp. 315–319, March 1984.
- [15] C. Fadhlika and K. Anwar, "Downscaled ldpc codes for indonesia digital video broadcasting terrestrial 2nd generation (DVB-T2)," in *IEEE Symposium on Future Telecommunication (SOFTT)*, Kuala Lumpur, Malaysia, November 2019.



Hilman Auzan Mulyono was born in Jakarta, March 11st 1998. Hilman is pursuing a Bachelor's Degree in Telecommunication Engineering at the School of Electrical Engineering, Telkom University. Hilman is a researcher in Advanced Wireless Technology (AdWiTech). Hilman takes a research topic about BCH codes for digital

television. His research interest include channel coding, modulation, digital television.



Khoirul Anwar (SM16) received the bachelors degree (cum laude) from the Department of Electrical Engineering (Telecommunications), Bandung Institute of Technology (ITB), Bandung, Indonesia, in 2000, and the masters and Ph.D. degrees from the Graduate School of Information Science, Nara Institute of Science and Technology, Nara, Japan, in 2005 and 2008, respectively. He was with the University of Melbourne, Australia, in 2007, the University of Oulu, Finland, in 2010, and Cranfield University, U.K., in 2018, as a Visiting Researcher. In 2008, he was with the School of Information Science, Japan Advanced Institute of Science and Technology, as an Assistant Professor. Since 2016, he has been with the School of Electrical Engineering, Telkom University, Bandung, as an Associate Professor, and the Director of the Center for Advanced Wireless Technologies (2016–2020) and the

Director of the Center for Advanced Intelligent Communications (AICOMS) since 2020. He has been the Chairman of WG Radio and Technologies of Indonesia 5G Forum and the Chairman of the Asia Pasific Telecommunity Wireless Group on Service and Applications, 2016-2019. Dr. Anwar is currently the Vice-chairman of the Asia Pasific Telecommunity Wireless Group, 2019-2021.

His research interests are network information theory, error correction coding, iterative decoding, coding for super-dense networks, and signal processing for wireless communications. His technique is adopted by the international telecommunication union (ITU), ITU-R standard No. ITU-R S.2173 Multi-Carrier-Based Transmission Techniques, and ITU-R S.1878 Multi-carrier Based Transmission Techniques for Satellite Systems. He is a Senior Member of the IEEE Information Theory Society and Communications Society.

He received the Best Student Paper Award at the IEEE Radio and Wireless Symposium 2006 (RWS06), CA, USA, the Best Paper Award of Indonesian Student Association (ISA 2007), Kyoto, Japan, in 2007, the Best Paper Presenter for the Advanced Technology at the International Conference on Sustainability for Human Security (SUSTAIN), Kyoto, in 2011, the Indonesian Diaspora Award for Innovation, Congress of Indonesian Diaspora, Los Angeles, USA, in 2012, the Achmad Bakrie Award 2014, Jakarta, in 2014, and the Anugerah of Internationally Recognized Contributions from the Governor of West Java, Indonesia, in 2016, the National Achievement Award from UKP-PIP Pancasila, Jakarta, in 2017, OCBC award of Innovation in August 2019. He serves as a reviewer for a number of main journals and conferences in the areas of wireless communications, coding theory, and signal processing, 5G and 6G.



Budi Prasetya completed his undergraduate studies in 2001 at the School of Technology Telkom, Bandung, Indonesia. In that year also began as an assistant Lecture at the same school. In 2006 finished his graduate studies at the Bandung Institute of

Technology and started to become a lecturer at the Telkom Telkom University. He is currently pursuing a Ph.D. degree in mobile communication at Bandung Institute of Technology, Indonesia. His current research interests include wireless communication, rotate modulation, adaptive modula-

tion and coding, resource allocation in OFDMA
(Orthogonal Frequency Division Multiple Access)
systems.